

Technical data sheet

Product features



Slicer gear, blade 300 mm plain

Model	SAP Code	00001186
--------------	-----------------	----------



- Blade type: Smooth
- Blade diameter [mm]: 300
- Cutting thickness [mm]: 0 - 14
- Useful Cut [mm]: 265 x210
- Transfer type: Snail
- Material: Aluminium
- Safety cover: transparent plexiglass
- Safety element: motor with fan and overheating protection
stainless steel blade guard
transparent finger protection
- Suitable consumer: suitable for large establishments
- Table position: Oblique
- On/Off button: Yes
- Continuous work limit: running time without limitation

SAP Code	00001186	Loading	230 V / 1N - 50 Hz
Net Width [mm]	580	Blade type	Smooth
Net Depth [mm]	480	Blade diameter [mm]	300
Net Height [mm]	515	Cutting thickness [mm]	0 - 14
Net Weight [kg]	20.80	Useful Cut [mm]	265 x210
Power electric [kW]	0.320		

Technical data sheet

Technical drawing



Slicer gear, blade 300 mm plain

Model

SAP Code

00001186

Model	A	B	C	D	E
GMS 220	275	375	380	445	370
GMS 250	275	430	425	525	380
GMS 275 XL	350	490	480	510	400
GMS 300	350	490	480	580	515

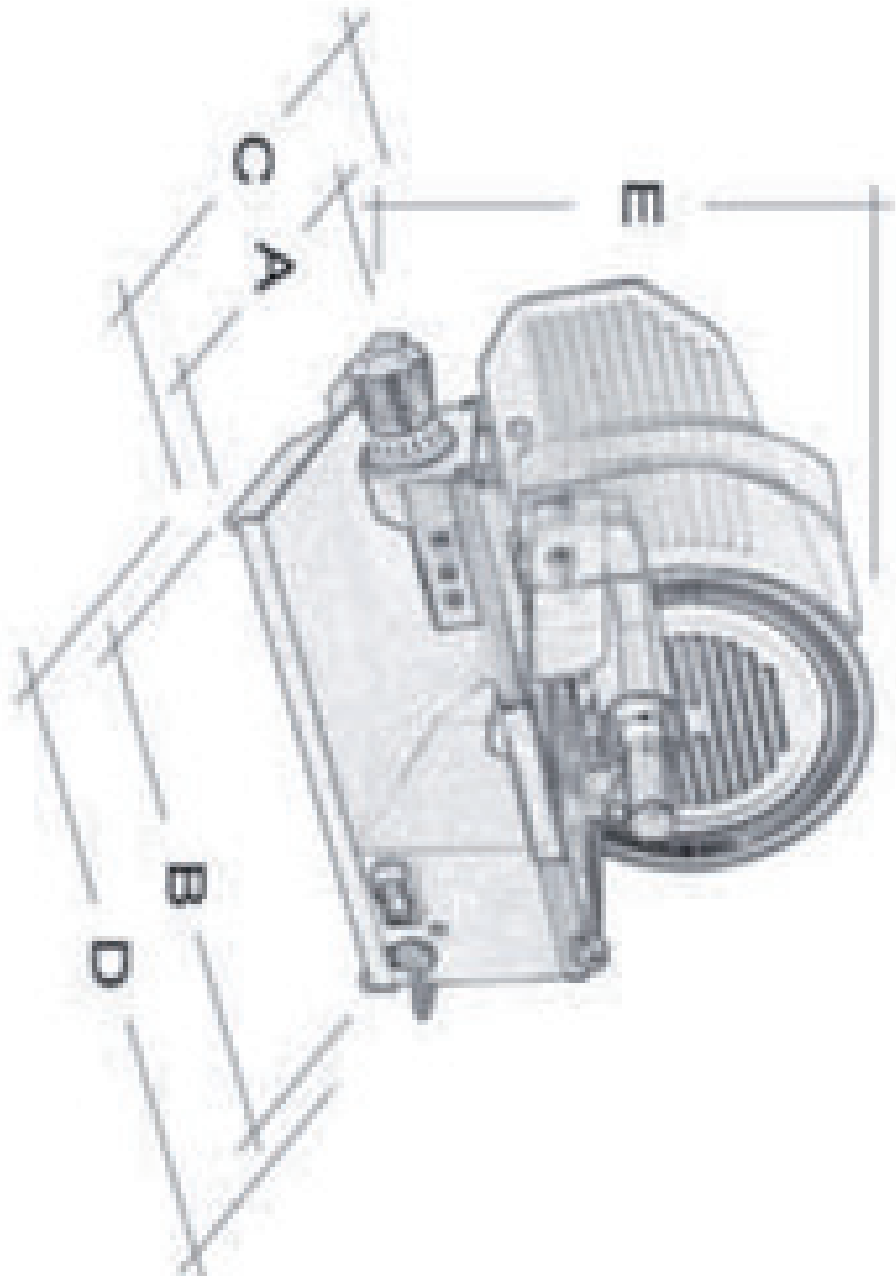

Technical data sheet

Product benefits



Slicer gear, blade 300 mm plain

Model

SAP Code

00001186

1

Aluminum alloy body

- robustness
purity
- long service life
 - very easy to clean

2

Worm gear

- long service life
- thanks to the worm gear and the more powerful motor, it can be used de facto continuously

3

Anti-stick treatment of the knife including anti-stick grooves

- less adhesion of the sliced food to the knife
- thanks to the blade design, even softer foods can be cut, saving costs and time

4

Fan-cooled motor with overheating protection

- greater capacity of processed food
long life
- can work longer thanks to cooling
 - less risk of overheating and engine damage due to cooling

5

Finger protection

- high operational safety
- the finger guard minimises the risk of accidents at work

6

Large blade diameter

- variability
- thanks to the large diameter of the knife, even large pieces of food can be processed

7

Grinding equipment included in the price

- guaranteed sharpness of the knife
quick maintenance
- no additional costs for external grinding
 - easy maintenance
 - immediate solution
 - time saving

Technical data sheet

Technical parameters



Slicer gear, blade 300 mm plain

Model

SAP Code

00001186

1. SAP Code:

00001186

2. Net Width [mm]:

580

3. Net Depth [mm]:

480

4. Net Height [mm]:

515

5. Net Weight [kg]:

20.80

6. Gross Width [mm]:

610

7. Gross depth [mm]:

530

8. Gross Height [mm]:

560

9. Gross Weight [kg]:

23.40

10. Device type:

Electric unit

11. Material:

Aluminium

12. Power electric [kW]:

0.320

13. Loading:

230 V / 1N - 50 Hz

14. Control type:

Mechanical

15. Safety cover:

transparent plexiglass

16. Safety element:

motor with fan and overheating protection
stainless steel blade guard
transparent finger protection

17. Suitable consumer:

suitable for large establishments

18. Engine protection:

fan and overheating protection

19. Start /stop:

Yes

20. Transfer type:

Snail

21. Blade type:

Smooth

22. Blade diameter [mm]:

300

23. Useful Cut [mm]:

265 x210

24. On/Off button:

Yes

25. Continuous work limit:

running time without limitation

26. Removable moving table:

Yes

Technical data sheet

Technical parameters



Slicer gear, blade 300 mm plain

Model

SAP Code

00001186

27. Anti-adhesive blade treatment:

Yes

30. Sharpening device:

Additional included in the price

28. Table position:

Oblique

31. Blade hardness:

58-59 HRC

29. Blade cover material:

Stainless steel

32. Cutting thickness [mm]:

0 - 14